

CATALOGUE

**ISOLATING
SWITCHING
AMPLIFIERS
POWER SUPPLIES**

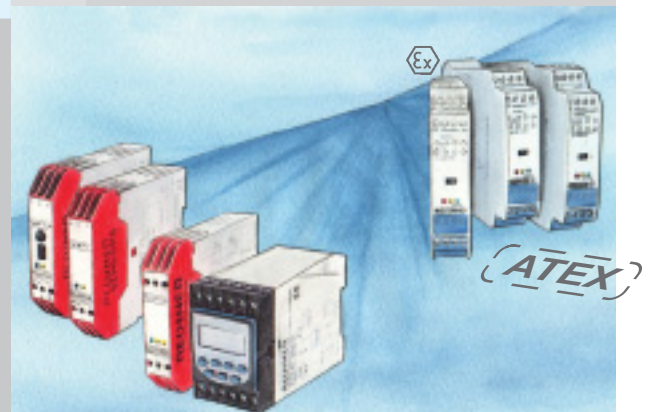



Registration No.: 1327-01



Testing laboratory accredited according to
DIN EN 45001 Reg.-No. DAT-P-048/95-00

For all transactions, the newest version of the „General Conditions of Sale and Delivery for Products and Services of the Electrical Industry ZVEI“ shall apply, along with the supplementary conditions „extended reservation of proprietary rights“, together with the supplements listed on our order confirmations and/or invoices.

All specifications are subject to change without notice. Reprint, even in part, only with our consent.

© RECHNER Germany 08/2004GB - Printed in EU, all rights reserved.

Edition August 2004

With publication of this catalogue all former printed catalogues about RECHNER isolating switching amplifiers and power supplies are invalid.

All specifications are subject to change without notice. (05/2004)

**CATALOGUE
ISOLATING SWITCHING AMPLIFIERS
POWER SUPPLIES**

Isolating switching Amplifier / ATEX	4-11
General information SERIES N-131/.....	4
Data sheet:	
..... N-131/1-01 230 V AC	5
..... N-131/1-02 115 V AC	6
..... N-131/1-10 20...30 V DC	7
..... N-131/2-01 230 V AC	8
..... N-131/2-02 115 V AC	9
..... N-131/2-10 20...30 V DC	10
..... N-131/2-E-10 20...30 V DC	11
..... N-130/4...20-IL	12
Power supplies EG...-130.....	13-17
General information SERIES EG-...-130.....	13
Data sheet:	
..... EGI-130 115/230 V AC	14
..... EGII-130 115/230 V AC	15
..... EGI-130-TD 115/230 V AC	16
..... EGI-130-MM 115/230 V AC	17
..... EGIII-130 24/48 V AC 115/230 V AC	18
Type selection	19
..... in article number order and type description order	

All specifications are subject to change without notice. (05/2004)



SERIES N-131...

The *Series N-131...* isolating switching amplifiers transmit switching operations from an intrinsically safe control circuit to a non-intrinsically safe active current circuit. The control units are designed according to NAMUR-DIN 19234 or EN 60947-5-6 intrinsically safe and according to EN 50014 and EN 50020 [EExia] II C. The conformity is certified in Germany by TÜV-NORD.

Power pack, switching amplifier, electronic evaluation unit and output relay are all integrated in the 22 mm sized housing. The units are EMV-approved according to IEC 801-2 to 5. Quick mounting is possible on profile according to DIN 46 277. LED displays are integrated in the front plate for stand-by (green), state of output (yellow) and wire-break/shortcircuit of the sensor cable (red).

The isolating switching amplifiers can be actuated by NAMUR sensors, e.g. our series IAS-30... and KAS-40..., or by mechanical contacts.



SERIES N-131...

The *Series N-131...* isolating switching amplifiers transmit switching operations from an intrinsically safe control circuit to a non-intrinsically safe active current circuit. The control units are designed according to NAMUR-DIN 19234 or EN 60947-5-6 intrinsically safe and according to EN 50014 and EN 50020 [EExia] II C. The conformity is certified in Germany by TÜV-NORD.

Power pack, switching amplifier, electronic evaluation unit and output relay are all integrated in the 22 mm sized housing. The units are EMV-approved according to IEC 801-2 to 5. Quick mounting is possible on profile according to DIN 46 277. LED displays are integrated in the front plate for stand-by (green), state of output (yellow) and wire-break/shortcircuit of the sensor cable (red).

The isolating switching amplifiers can be actuated by NAMUR sensors, e.g. our series IAS-30... and KAS-40..., or by mechanical contacts.



Certificate: TÜV 02 ATEX 1869



Isolating Switching Amplifier N-131/1-01 230 V AC • Ex II(1) G D [EEx ia] IIC

To connect **one NAMUR-Sensor** or potential-free mechanical contact. NAMUR sensors have to be connected to terminal 5 (+) with the brown wire and 7 (-) with the blue wire.

Mechanical contacts also have to be connected to terminals 5 and 7. A wire-bridge has to be connected between terminals 5 and 6, for switching off the wire-break/short-circuit control or a resistor connection has to be made (in series to the contact 2,7 k Ω and parallel to the contact 10 k Ω).

The NO/NC-programming of the output relay is possible by means of coding switches in the front plate:

Switch position I = NO (factory set).

Switch position II = NC if a KAS-40-... is connected

The functions are reversed with connection of an IAS-30-...

Technical data

Operating voltage (U _B)	230 V AC \pm 10% 48...62 Hz
Output function	1 x change-over contact potential-free
Contact rating each relay AC max.	250 V AC/ 5 A/ 100 VA
Contact rating each relay DC max.	24 V DC/ 8 A/ 50 W
Type	N-131/1-01
Art.-No.	N00005
Connection diagram No.	see below
No-load current (I ₀)	typ. 15 mA
No-load voltage max. (U ₀)	10.5 V DC
Short-circuit current max. (I _k)	26 mA
Outer inductance max. (L ₀)	[EExia] IIC 45 mH/ IIB 160 mH
Outer capacitance max. (C ₀)	[EExia] IIC 2.41 μ F/ IIB 16.8 μ F
Actuating signal	NAMUR DIN 19234 or EN 60947-5-6
Permitted ambient temperature	-20...+60°C
Display	red/yellow and green
Degree of protection IEC 529	housing: IP 30 terminals: IP 20
Connection	screw terminals

All specifications are subject to change without notice. (08/2004)

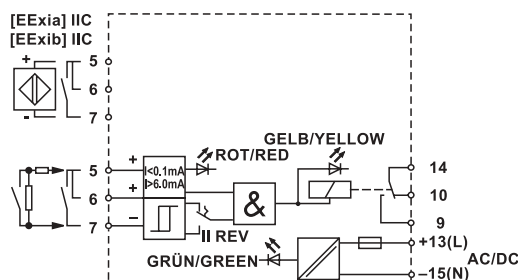
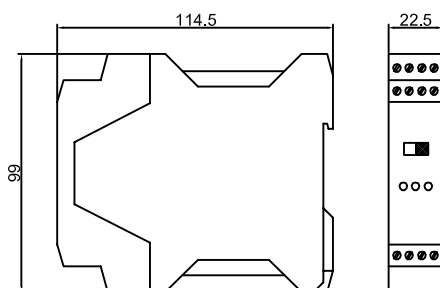

N-131/1-01
SWITCH AMPLIFIER
SCHALTERVERSTÄRKER



Isolating Switching Amplifier N-131/1-02 115 V AC • Ex II(1) G D [EEx ia] IIC

To connect **one NAMUR-Sensor** or potential-free mechanical contact. NAMUR sensors have to be connected to terminal 5 (+) with the brown wire and 7 (-) with the blue wire.

Mechanical contacts also have to be connected to terminals 5 and 7. A wire-bridge has to be connected between terminals 5 and 6, for switching off the wire-break/short-circuit control or a resistor connection has to be made (in series to the contact 2,7 k Ω and parallel to the contact 10 k Ω).

The NO/NC-programming of the output relay is possible by means of coding switches in the front plate:

Switch position I = NO (factory set),

Switch position II = NC if a KAS-40-... is connected

The functions are reversed with connection of an IAS-30-...

Certificate: TÜV 02 ATEX 1869



Technical data

Operating voltage (U_B)	115 V AC \pm 10% 48...62 Hz
Output function	1 x change-over contact potential-free
Contact rating each relay AC max.	250 V AC/ 5 A/ 100 VA
Contact rating each relay DC max.	24 V DC/ 8 A/ 50 W
Type	N-131/1-02
Art.-No.	N00006
Connection diagram No.	see below
No-load current (I_0)	typ. 15 mA
No-load voltage max. (U_0)	10,5 V DC
Short-circuit current max. (I_k)	26 mA
Outer inductance max. (L_0)	[EExia] IIC 45 mH/ IIB 160 mH
Outer capacitance max. (C_0)	[EExia] IIC 2.41 μ F/ IIB 16.8 μ F
Actuating signal	NAMUR DIN 19234 or EN 60947-5-6
Permitted ambient temperature	-20...+60°C
Display	red/yellow and green
Degree of protection IEC 529	housing: IP 30 terminals: IP 20
Connection	screw terminals

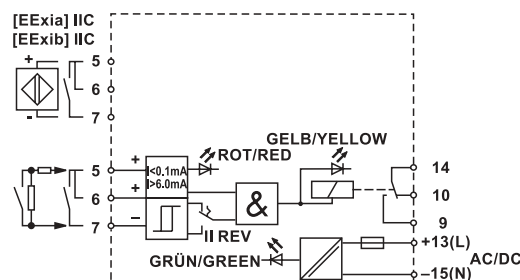
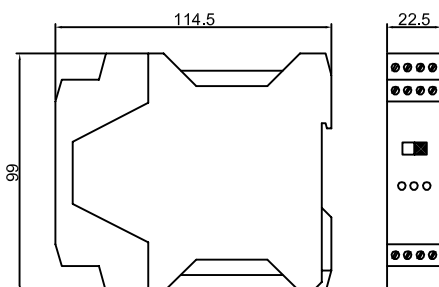

N-131/1-02
SWITCH AMPLIFIER
SCHALTVERSTÄRKER

All specifications are subject to change without notice. (08/2004)



Isolating Switching Amplifier N-131/1-10 20...30 V DC • Ex II(1) G D [EEx ia] IIC

To connect **one NAMUR-Sensor** or potential-free mechanical contact. NAMUR sensors have to be connected to terminal 5 (+) with the brown wire and 7 (-) with the blue wire.

Mechanical contacts also have to be connected to terminals 5 and 7. A wire-bridge has to be connected between terminals 5 and 6, for switching off the wire-break/short-circuit control or a resistor connection has to be made (in series to the contact 2,7 k Ω and parallel to the contact 10 k Ω).

The NO/NC-programming of the output relay is possible by means of coding switches in the front plate:

Switch position I = NO (factory set),

Switch position II = NC if a KAS-40-... is connected

The functions are reversed with connection of an IAS-30-...

Certificate: TÜV 02 ATEX 1869



Technical data

Operating voltage (U_b)	20...30 V DC
Output function	1 x change-over contact potential-free
Contact rating each relay AC max.	250 V AC/ 5 A/ 100 VA
Contact rating each relay DC max.	24 V DC/ 8 A/ 50 W
Type	N-131/1-10
Art.-No.	N00007
Connection diagram No.	see below
No-load current (I_b)	typ. 15 mA
No-load voltage max. (U_b)	10.5 V DC
Short-circuit current max. (I_k)	26 mA
Outer inductance max. (L_o)	[EExia] IIC 45 mH/ IIB 160 mH
Outer capacitance max. (C_o)	[EExia] IIC 2.41 μ F/ IIB 16.8 μ F
Actuating signal	NAMUR DIN 19234 or EN 60947-5-6
Permitted ambient temperature	-20...+60°C
Display	red/yellow and green
Degree of protection IEC 529	housing: IP 30 terminals: IP 20
Connection	screw terminals

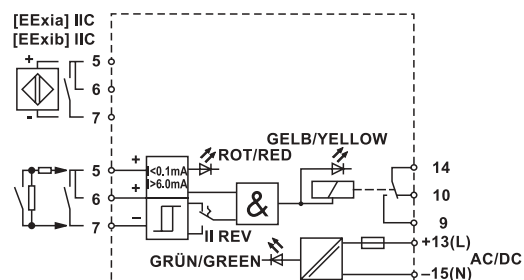
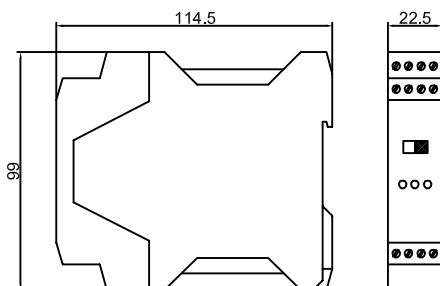

N-131/1-10 SWITCH AMPLIFIER
SCHALTERVERSTÄRKER

All specifications are subject to change without notice. (08/2004)



Certificate TÜV 02 ATEX 1869



Isolating Switching Amplifier N-131/2-01 230 V AC • Ex II(1) G D [EEx ia] IIC

To connect **two NAMUR-Sensors** or potential-free mechanical contacts. NAMUR sensors have to be connected to terminals 1 or 5 (+) with the brown wire and 3 or 7 (-) with the blue wire.

Mechanical contacts also have to be connected to terminals 1, 3 (channel 2) or 5, 7 (Channel 1). A wire-bridge has to be connected between terminals 1, 2 (channel 2) or 5, 6 (channel 1), for switching off the wire-break/short-circuit control or a resistor connection has to be made (in series to the contact 2,7 k Ω and parallel to the contact 10 k Ω).

The NO/NC-programming of the output relay is possible by means of coding switches in the front plate:

Switch position I = NO (factory set),

Switch position II = NC if a KAS-40-... is connected

The functions are reversed with connection of an IAS-30-...

Technical data

Operating voltage (U_0)	230 V AC \pm 10% 48...62 Hz
Output function	2 x change-over contacts potential-free
Contact rating each relay AC max.	250 V AC/ 5 A/ 100 VA
Contact rating each relay DC max.	24 V DC/ 8 A/ 50 W
Type	N-131/2-01
Art.-No.	N00001
Connection diagram No.	see below
No-load current (I_0)	typ. 15 mA
No-load voltage max. (U_0)	10.5 V DC
Short-circuit current max. (I_k)	26 mA
Outer inductance max. (L_0)	[EExia] IIC 45 mH/ IIB 160 mH
Outer capacitance max. (C_0)	[EExia] IIC 2.41 μ F/ IIB 16.8 μ F
Actuating signal	NAMUR DIN 19234 or EN 60947-5-6
Permitted ambient temperature	-20...+60°C
Display	red/yellow and green
Degree of protection IEC 529	housing: IP 30 terminals: IP 20
Connection	screw terminals

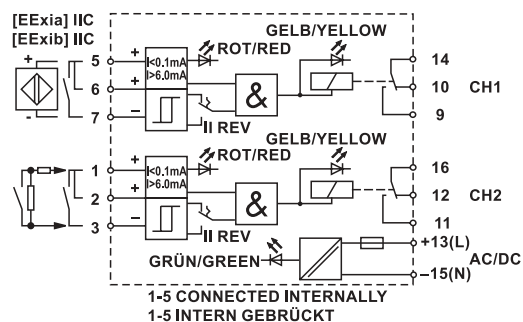
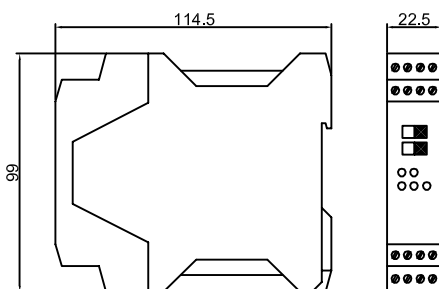

N-131/2-01
SWITCH AMPLIFIER
SCHALTVERSTÄRKER

All specifications are subject to change without notice. (08/2004)



Isolating Switching Amplifier N-131/2-02 115 V AC • Ex II(1) G D [EEEx ia] IIC

To connect **two NAMUR-Sensors** or potential-free mechanical contacts. NAMUR sensors have to be connected to terminals 1 or 5 (+) with the brown wire and 3 or 7 (-) with the blue wire.

Mechanical contacts also have to be connected to terminals 1, 3 (channel 2) or 5, 7 (channel 1). A wire-bridge has to be connected between terminals 1, 2 (channel 2) or 5, 6 (channel 1), for switching off the wire-break/short-circuit control or a resistor connection has to be made (in series to the contact 2,7 k Ω and parallel to the contact 10 k Ω).

The NO/NC-programming of the output relay is possible by means of coding switches in the front plate:

Switch position I = NO (factory set),

Switch position II = NC if a KAS-40-... is connected

The functions are reversed with connection of an IAS-30-...

Certificate: TÜV 02 ATEX 1869



Technical data

Operating voltage (U_b)	115 V AC \pm 10% 48...62 Hz
Output function	2 x change-over contacts potential-free
Contact rating each relay AC max.	250 V AC/ 5 A/ 100 VA
Contact rating each relay DC max.	24 V DC/ 8 A/ 50 W
Type	N-131/2-02
Art.-No.	N00002
Connection diagram No.	see below
No-load current (I_b)	typ. 15 mA
No-load voltage max. (U_0)	10.5 V DC
Short-circuit current max. (I_k)	26 mA
Outer inductance max. (L_0)	[EEExia] IIC 45 mH/ IIB 160 mH
Outer capacitance max. (C_0)	[EEExia] IIC 2.41 μ F/ IIB 16.8 μ F
Actuating signal	NAMUR DIN 19234 or EN 60947-5-6
Permitted ambient temperature	-20...+60°C
Display	red/yellow and green
Degree of protection IEC 529	housing: IP 30 terminals: IP 20
Connection	screw terminals

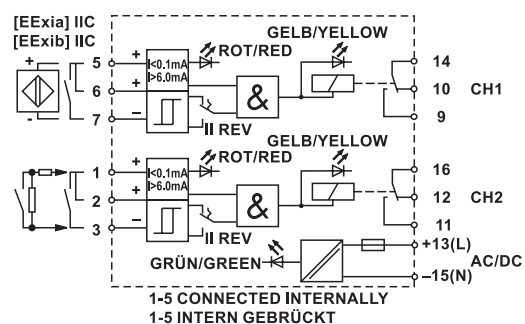
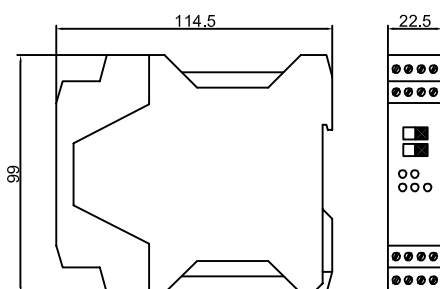

N-131/2-02 SWITCH AMPLIFIER SCHALTERSTÄRKER

All specifications are subject to change without notice. (08/2004)



Certificate: TÜV 02 ATEX 1869



Isolating Switching Amplifier N-131/2-10 20...30 V DC • Ex II(1) G D [EEx ia] IIC

To connect **two NAMUR-Sensors** or potential-free mechanical contacts. NAMUR sensors have to be connected to terminals 1 or 5 (+) with the brown wire and 3 or 7 (-) with the blue wire.

Mechanical contacts also have to be connected to terminals 1, 3 (channel 2) or 5, 7 (channel 1). A wire-bridge has to be connected between terminals 1, 2 (channel 2) or 5, 6 (channel 1), for switching off the wire-break/short-circuit control or a resistor connection has to be made (in series to the contact 2,7 k Ω and parallel to the contact 10 k Ω).

The NO/NC-programming of the output relay is possible by means of coding switches in the front plate:

Switch position I = NO (factory set),

Switch position II = NC if a KAS-40-... is connected

The functions are reversed with connection of an IAS-30-...

Technical data

Operating voltage (U_B)	20...30 V DC
Output function	2 x change-over contacts potential-free
Contact rating each relay AC max.	250 V AC/ 5 A/ 100 VA
Contact rating each relay DC max.	24 V DC/ 8 A/ 50 W
Type	N-131/2-10
Art.-No.	N00003
Connection diagram No.	see below
No-load current (I_0)	typ. 15 mA
No-load voltage max. (U_0)	10.5 V DC
Short-circuit current max. (I_k)	26 mA
Outer inductance max. (L_0)	[EExia] IIC 45 mH/ IIB 160 mH
Outer capacitance max. (C_0)	[EExia] IIC 2.41 μ F/ IIB 16.8 μ F
Actuating signal	NAMUR DIN 19234 or EN 60947-5-6
Permitted ambient temperature	-20...+60°C
Display	red/yellow and green
Degree of protection IEC 529	housing: IP 30 terminals: IP 20
Connection	screw terminals

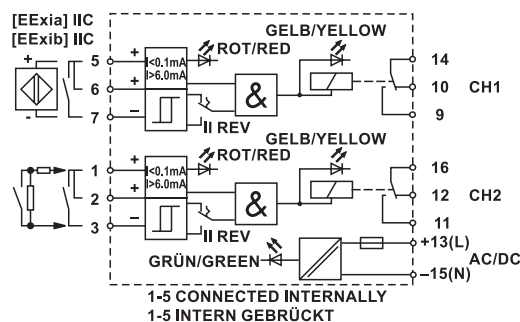
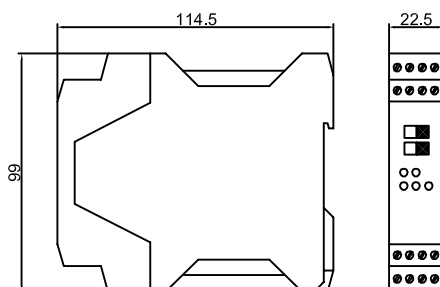

N-131/2-10
SWITCH AMPLIFIER
SCHALTERVERSTÄRKER

All specifications are subject to change without notice. (08/2004)



Isolating Switching Amplifier • PNP Output
N-131/2-E-10 20...30 V DC • Ex II(1) G D [EEx ia] IIC

To connect **two NAMUR-Sensors** or potential-free mechanical contacts. NAMUR sensors have to be connected to terminals 1 or 5 (+) with the brown wire and 3 or 7 (-) with the blue wire. Mechanical contacts also have to be connected to terminals 1, 3 (channel 2) or 5, 7 Channel 1). A wire-bridge has to be connected between terminals 1, 2 (channel 2) or 5, 6 (channel 1), for switching off the wire-break/short-circuit control or a resistor connection has to be made (in series to the contact 2,7 k Ω and parallel to the contact 10 k Ω). The active electrical outputs are connected to terminal 9 (channel 1) and 11 (channel 2). The terminals 14 and 16 are internally bridged to terminal 13 (+24V),

The NO/NC-programming of the output relay is possible by means of coding switches in the front plate:

- Switch position I** = NO (factory set),
 - Switch position II** = NC if a KAS-40-... is connected
- The functions are reversed with connection of an IAS-30-...

• Because of the PNP output, suitable for switching frequency **up to 1 kHz**.

Certificate: TÜV 02 ATEX 1869



Technical data

Operating voltage (U_b)	20 - 30 V DC
Output function	2 x transistor output pnp
Operating voltage max.	35 V DC
Operating current max.	100 mA
Switching capacity max.	3,5 W
Type	N-131/2-E-10
Art.-No.	N00004
Connection diagram No.	see below
No-load current (I_0)	typ. 15 mA
No-load voltage max. (U_0)	10.5 V DC
Short-circuit current max. (I_k)	26 mA
Outer inductance max. (L_0)	[EExia] IIC 45 mH/ IIB 160 mH
Outer capacitance max. (C_0)	[EExia] IIC 2.41 μ F/ IIB 16.8 μ F
Actuating signal	NAMUR DIN 19234 or EN 60947-5-6
Permitted ambient temperature	-20...+60°C
Display	red/yellow and green
Degree of protection IEC 529	housing: IP 30 terminals: IP 20
Connection	screw terminals

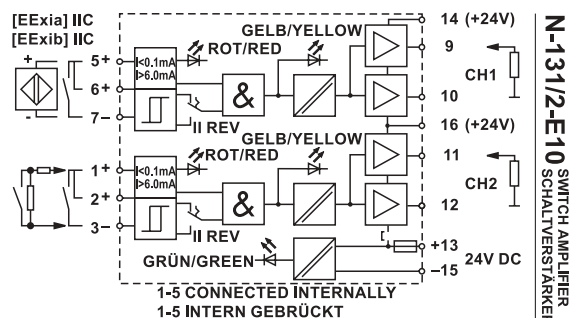
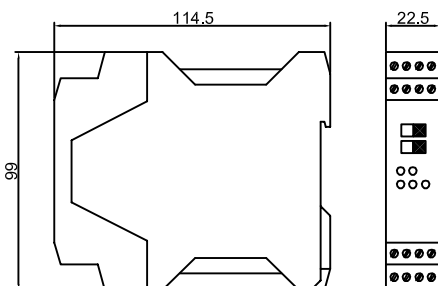

All specifications are subject to change without notice. (08/2004)

POWER SUPPLIES - SERIES EG-...-130...

The EG-...-130-... series control units contain a DC-side short-circuit protected power pack, voltage stabiliser and output relay. The 22 mm small housing is designed for quick mounting on DIN 46 277 profiles (housing size 70 mm for EG III-...). LED displays are integrated in the front panel for standby and state of output. When a sensor is connected to the unit, it automatically recognises whether the sensor is PNP or NPN output.

These control units can be actuated by all 2, 3 and 4-wire sensors with PNP, NPN, NO, NC or antivalent function, i. e. our series IAS-10..., IAS-20..., IAS-60..., KAS-70..., KAS-80..., KAS-90..., IS-120... and SW-600.

The model EG III-130 can also be connected to one of our KXA-.../ KFA-... or KFX-... sensor systems. Details of the parameters to be considered when connecting these systems, are available on request.



Power Supply EG I-130 Series 130 - Relay Output

- To connect one 2, 3 or 4-wire sensor with NPN or PNP transistor output. When connecting an antivalent sensor (4-wire) the NO or NC output can be connected.
- With one output relay (1 x changeover)

Certificate:



Technical Data

Operating voltage (U_B)	115/230 V AC \pm 15% 40...60 Hz
No-load current (I_0)	typ. 20mA
Output function	1 x potential-free change-over contact
Contact rating each relay max..	250 V AC/ 6 A
Type	EGI-130
Art.-No.	522 000
Connection drawing	see below
Actuating voltage (U_s)	24 V DC \pm 20%
Actuating current max. (I_s)	60 mA
Residual ripple acc. to DIN 41 755 max.	2 %
Actuating signal	pnp or npn
Permitted ambient temperature	-25...+80°C
Display	LED green and yellow
Degree of protection IEC 529	housing: IP 30 connections: IP 20
Connection	screw terminals

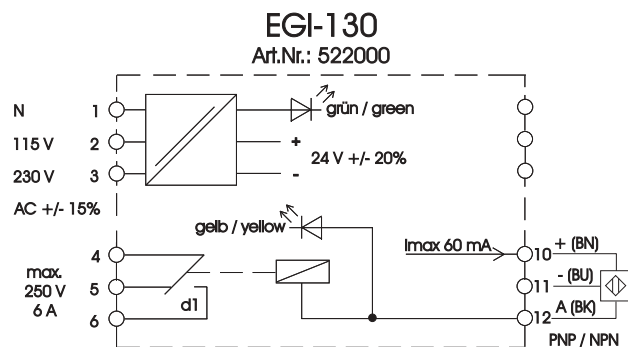
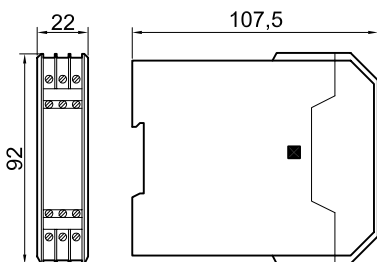

All specifications are subject to change without notice. (05/2004)



Power Supply EG II-130 Series 130 - Relay Output

- To connect two 2, 3 or 4-wire sensors with NPN or PNP transistor output (not from our series SW-600). When connecting one antivalent sensor (4-wire) both outputs, NO and NC, can be connected. When connecting two antivalent sensors only one output of each can be connected.
- With two output relays (1 x changeover and 1 x normally open)

Certificate:



Technical Data

Operating voltage (U_B)	115/230 V AC \pm 15% 40...60 Hz
No-load current (I_0)	typ. 40mA
Output function	1 x potential-free change-over contact / 1 x potential-free NO
Contact rating each relay max..	250 V AC / 6 A
Type	EGII-130
Art.-No.	522 300
Connection drawing	see below
Actuating voltage (U_s)	24 V DC \pm 20%
Actuating current max. (I_s)	60 mA
Residual ripple acc. to DIN 41 755 max.	2 %
Actuating signal	pnp or npn
Permitted ambient temperature	-25...+80°C
Display	LED green and yellow
Degree of protection IEC 529	housing: IP 30 connections: IP 20
Connection	screw terminals

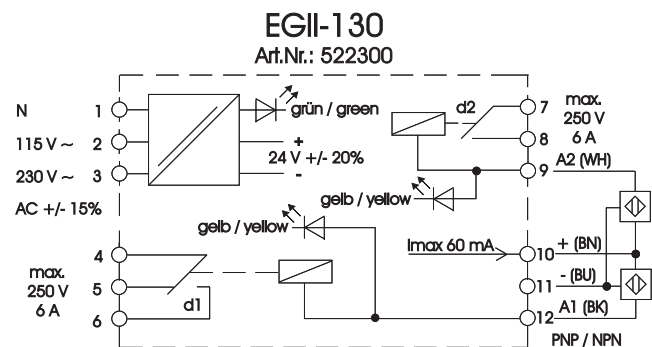
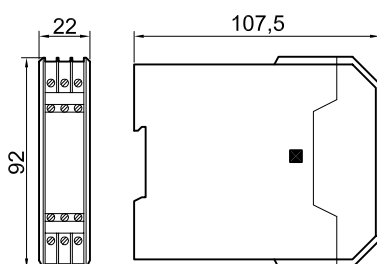

All specifications are subject to change without notice. (05/2004)



Certificate:



Power Supply EG I-130-TD Series 130 - Relay Output With Time Delay

- To connect one 2, 3 or 4-wire sensor with NPN or PNP transistor output. When connecting an antivalent sensor (4-wire) the NO or NC output can be connected.
- With one output relay (1 x changeover)
- This control unit provides an energising or de-energising delay, which is programmable by a switch:
A = energising delay, B = de-energising delay.

Technical Data

Operating voltage (U_B)	115/230 V AC \pm 15% 40...60 Hz
No-load current (I_0)	typ. 20mA
Output function	1 x potential-free change-over contact
Contact rating each relay max..	250 V AC/ 6 A
Type	EGI-130-TD
Art.-No.	522 100
Connection drawing	see below
Actuating voltage (U_s)	24 V DC \pm 20%
Actuating current max. (I_s)	60 mA
Residual ripple acc. to DIN 41 755 max.	2 %
Actuating signal	pnp or npn
Permitted ambient temperature	-25...+80°C
Display	LED green and yellow energising and de-energising delay $t_1 = 0,1...5$ s/ $t_2 = 2...60$ s
Degree of protection IEC 529	housing: IP 30 connections: IP 20
Connection	screw terminals

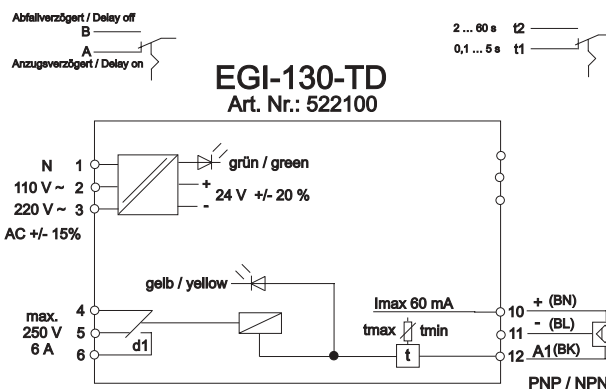
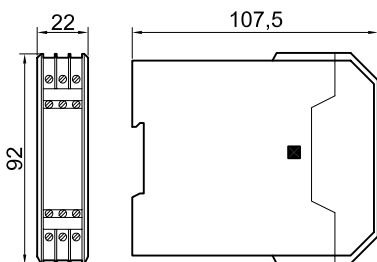

All specifications are subject to change without notice. (05/2004)



Power Supply EG I-130-MM Series 130 - Relay Output- MIN/MAX-Control

- To connect two 2 or 3-wire sensors in NO-function with NPN or PNP transistor output. When connecting antivalent sensors the NO-output can be connected.
- Integrated MIN/MAX-Control
- With one output relay (1 x changeover)

Certificate:



Technical Data

Operating voltage (U_B)	115/230 V AC \pm 15% 40...60 Hz
No-load current (I_0)	typ. 20mA
Output function	1 x potential-free change-over contact
Contact rating each relay max..	250 V AC / 6 A
Type	EGI-130-MM
Art.-No.	522 200
Connection drawing	see below
Actuating voltage (U_s)	24 V DC \pm 20%
Actuating current max. (I_s)	60 mA
Residual ripple acc. to DIN 41 755 max.	2 %
Actuating signal	pnp or npn
Permitted ambient temperature	-25...+80°C
Display	LED geen or yellow min./max. -Control
Degree of protection IEC 529	housing: IP 30 connections: IP 20
Connection	screw terminals

All specifications are subject to change without notice. (05/2004)

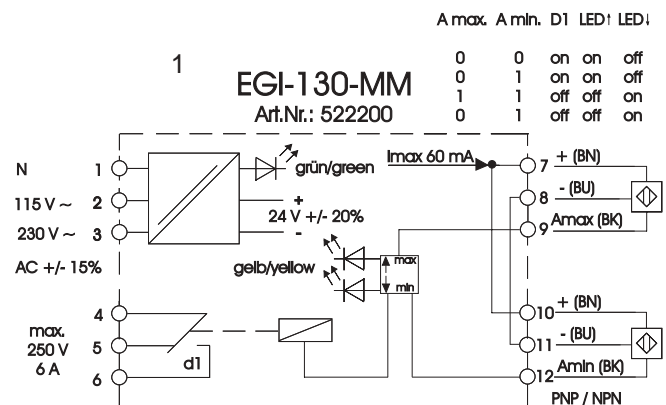
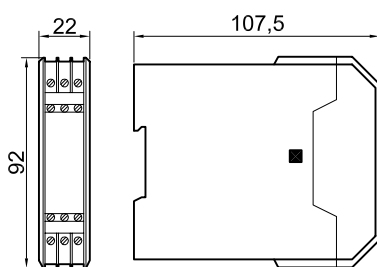



Power Supply EG III Series 130 - Relay Output

- To connect three 2, 3 or 4-wire sensors with NPN or PNP transistor output. When connecting an antivalent sensor (4-wire) the NO or NC output can be connected
- With three output relays

Certificate:



Technical Data

Operating voltage (U_B)	24/48 V AC \pm 15% 40...60 Hz	115/230 V AC \pm 15% 40...60 Hz
No-load current (I_0)	typ. 40mA	
Output function	3 x potential-free change-over contact	
Contact rating each relay max..	250 V AC/ 6 A	
Type	EGIII-130 24/48 VAC	EGIII-130 115/230 VAC
Art.-No.	NA 0003	NA 0002
Connection drawing	see below	
Actuating voltage (U_s)	24 V DC \pm 20%	
Actuating current max. (I_s)	100 mA	
Residual ripple acc. to DIN 41 755 max.	2 %	
Actuating signal	pnp or npn	
Permitted ambient temperature	-25...+70°C	
Display	LED green and yellow	
Degree of protection IEC 529	housing: IP 30 connections: IP 20	
Connection	screw terminals	

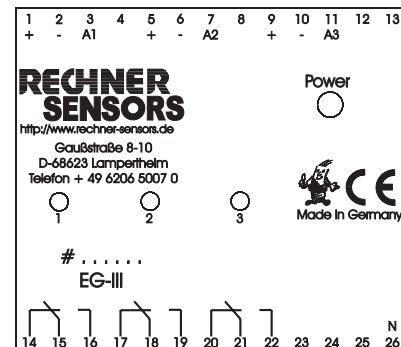
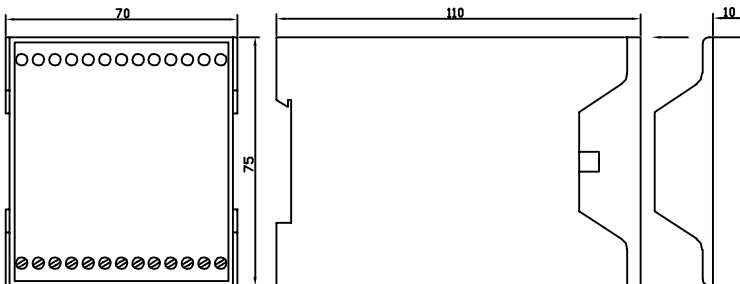

230V/48V
L1
115V/24V
L1

All specifications are subject to change without notice. (07/2004)

TYPE SELECTION IN ARTICLE NUMBER ORDER

Art.-No.	Description	Page
513780	N-130/4-20-IL	12
522000	EGI-130	14
522100	EGI-130-TD	16
522200	EGI-130-MM	17
522300	EGII-130	15
N00001	N-131/2-01	8
N00002	N-131/2-02	9
N00003	N-131/2-10	10
N00004	N-131/2-E-10	11
N00005	N-131/1-01	5
N00006	N-131/1-02	6
N00007	N-131/1-10	7
NA 0002	EGIII-130 115/230 VAC	18
NA 0003	EGIII-130 24/48 VAC	18

TYPE SELECTION IN TYPE DESCRIPTION ORDER

Description	Art.-No.	Page
EGI-130	522000	14
EGI-130-MM	522200	17
EGI-130-TD	522100	16
EGII-130	522300	15
EGIII-130 115/230 VAC	NA 0002	18
EGIII-130 24/48 VAC	NA 0003	18
N-130/4-20-IL	513780	12
N-131/1-01	N00005	5
N-131/1-02	N00006	6
N-131/1-10	N00007	7
N-131/2-01	N00001	8
N-131/2-02	N00002	9
N-131/2-10	N00003	10
N-131/2-E-10	N00004	11

All specifications are subject to change without notice. (05/2004)

SENSORS FOR INDUSTRIAL AUTOMATION

**INDUCTIVE • CAPACITIVE
OPTOELECTRONIC • MAGNETORESISTIVE
CALORIMETRIC**

ASK for further catalogues:

INDUCTIVE SENSORS

CAPACITIVE SENSORS KAS

CAPACITIVE SENSORS KXS

MAGNETORESISTIVE SENSORS

OPTOELECTRONIC SENSORS

CAPACITIVE LEVEL MEASURING SYSTEMS

FLOW SENSORS

Your Representative

RECHNER

INDUSTRIE-ELEKTRONIK GmbH

Gaußstraße 8-10 68623 Lampertheim Germany

Tel. 06206/5007-0 Fax 06206/5007 36 Fax Intl. +496206-500720

www.rechner-sensors.de

e-mail: info@rechner-sensors.de