

CATALOGUE

***MAGNETO-
RESISTIVE
SENSORS
MRS***

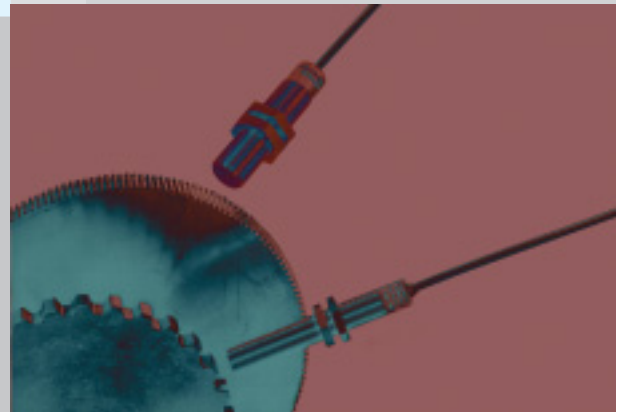



Registration No.: 1327-01



Testing laboratory accredited according to
DIN EN 45001 Reg.-No. DAT-P-048/95-00

For all transactions, the newest version of the „General Conditions of Sale and Delivery for Products and Services of the Electrical Industry ZVEI“ shall apply, along with the supplementary conditions „extended reservation of proprietary rights“, together with the supplements listed on our order confirmations and/or invoices.

All specifications are subject to change without notice. Reprint, even in part, only with our consent.

© RECHNER Germany 05/2004GB - Printed in EU, all rights reserved.

Edition May 2004

With publication of this catalogue all former printed catalogues about RECHNER magneto-resistive sensors are invalid.

All specifications are subject to change without notice. (05/2004)

TABLE OF CONTENTS

CATALOGUE MAGNETO-RESISTIVE SENSORS MRS

	PAGES
TECHNOLOGY • MOUNTING • APPLICATION	4-6
ADJUSTMENT	6
TECHNICAL TERMS	7
APPLICATION EXAMPLES	8
TYPE CODE	9
CYLINDRICAL HOUSINGS	11-19
NORMS	20-21
TYPE SELECTION IN ARTICLE NUMBER ORDER	22
TYPE SELECTION IN TYPE DESCRIPTION ORDER	22

All specifications are subject to change without notice. (05/2004)

TECHNOLOGY • MOUNTING • APPLICATION

The **magneto-resistive sensors (MRS)** detect the movement of ferromagnetic materials, by means of the change of the magnetic flow. They are suitable for rotary speed sensing, for detection of gearwheels and for standstill control. Areas of use can be heavy construction engines, rail vehicles, large diesel engines and turbines.

The magneto-resistive sensors (MRS) work like a magnetic Wheatstone bridge. They react to all ferromagnetic materials. The tooth or gap of a gearwheel, which passed the active area of the sensor, have a different influence on the magnetic field. This results in a change of the magnet-field dependent resistor. This change of the magnetic field is transformed to an electrical voltage-bridge, which then is filtered and prepared. The output signal is a voltage, which corresponds to the magnetfield change.

We have two different series:

⇒ Series 300-S ...-N	3-wire PNP or NPN 2-wire
⇒ Series 350	...-S ...-Z	4-wire PNP or NPN 4-wire PNP with dephased output signal
	with detection of direction of rotation	

The components of the MRS are mounted in plastic or metal casings and encapsulated with epoxy casting resin.

The plastics used for the housings are:

- ⇒ PA (polyamide) 6.6 glass-fibre reinforced
- ⇒ PEEK (polyetheretherketone)

And the metal housings are

- ⇒ VA stainless-steel, material No. 1.4404 or No. 1.4305.
- ⇒ MS brass/chrome or nickel-plated

Since the active area is made from a block material the degree of protection IP 68 is achieved on the front end.

Only pre-tested electronic components, proven integrated circuits and hybrid circuits are used and produced with SMT. The standard constant ambient temperature permitted is dependent on the model from -40 up to +125°C (see data sheet).

With contactless detection no physical actuating force is required for operation. There is no contact bounce, no sensor wear, no maintenance and the service life is independent of the switching frequency.

MRS can be used in machines, systems and vehicles for contactless detection, for monitoring and positioning, as a pulse generator for counting tasks and speed measurements, and for many other applications (for application examples see page 8).

Wiring of the MRS should be routed separately or screened from heavy conductor lines, as in extreme cases inductive peak voltages can destroy the sensors despite the integrated protective circuit. Screened cable or twisted lines are recommended, especially for longer cable runs > 5 m. Direct control of electric light bulbs is to be avoided, because during the switch-on moment cold current is many times the rated current and can destroy the output stage of the sensor.

Units with strong local field power, e. g. high power walkie-talkies, or noise sources in the lower frequency range, e.g. long, middle or short wave transmitters should not be operated close to the sensors or additional measures have to be taken in order to eliminate the maloperation.

2- and 3-wire sensors with binary output can be used in series or parallel connection, similar to mechanical contacts. It is important to note the type-typical voltage drop and the residual voltage U_d , that must be multiplied, for series connection, in accordance with the number of sensors.

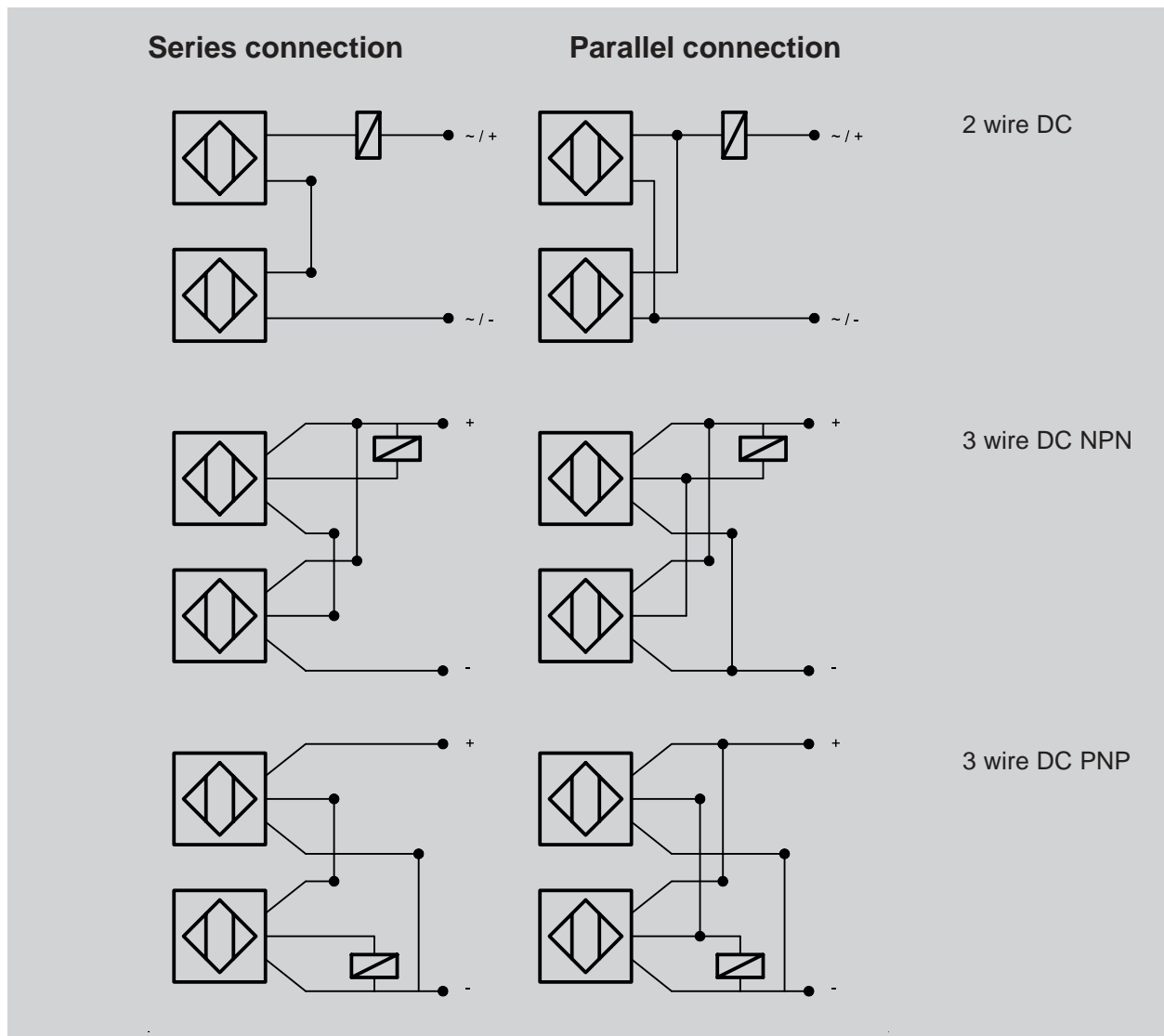

All specifications are subject to change without notice. (05/2004)

The material and version-dependent **maximum torque** should be taken into consideration when mounting, in order to prevent damage to the threaded sleeves. The values listed in the table are based on the use of the nuts supplied with the sensors.

Thread	Housing Material				
	PVC	PA 6.6	PTFE	Brass	Stainless Steel
M 5 x 0.5	-	-	-	-	1.5 Nm
M 8 x 1	-	-	-	-	4.5 Nm
M 12 x 1	1.5 Nm	1 Nm	0.2 Nm	16 Nm	25 Nm
M 18 x 1	-	1.7 Nm	0.5 Nm	28 Nm	60 Nm
M 22 x 1.5	12 Nm	6 Nm	1.4 Nm	32 Nm	84 Nm
M 30 x 1.5	-	8 Nm	2.5 Nm	82 Nm	200 Nm
M 32 x 1.5	-	13 Nm	3 Nm	150 Nm	230 Nm

Due to the permitted thread tolerances specified in German standard DIN 13, the **maximum screw-in length** for threaded sensors should be taken into consideration. Depending on that the length of the threaded block for screwing in proximity sensors should not exceed the following dimensions. In the case of larger threaded blocks we recommend drilling a blind hole in order to adhere to the maximum screw-in length.

Thread:	M 5 x 0.5	M 8 x 1	M 12 x 1	M18 x 1	M 22 x 1.5	M 30 x 1.5	M 32 x 1.5
Screw-in length max.	3 mm	6 mm	8 mm	12 mm	12 mm	12 mm	12 mm

ADJUSTMENT

Speed sensing is possible with gearwheels down to **module 1** at a maximum switching frequency of 15 kHz. For detecting rotary speed/direction of rotation magnetoresistive sensors (MRS) must be mounted radially with respect to the direction of motion and with their marking set vertically to it.

The dependence of the modul of the detected gearwheel on the mounting distance and the maximum detecting frequency is as follows:

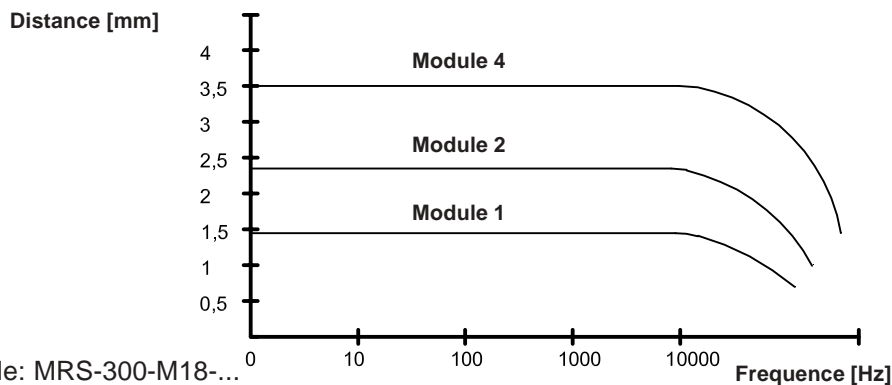

All specifications are subject to change without notice. (05/2004)

TECHNICAL TERMS

Unless otherwise specified technical data is as follows: +24°C, $U_B = 24$ V DC

Operating sensing distance / S_a

Within the operating sensing distance the sensor operates reliably taking in to account all the possible tolerances. It lies between 0 and $0.81 \times S_n$.

Power up time delay

The time the sensor needs to be ready for operation after connecting the operating voltage. It is in the milliseconds range.

Housing materials

The application of the housing materials used is based on the technical specifications of the material and of the manufacturer. The customer is responsible for checking in each case that the housing material is suitable for the application, even though RECHNER Sensors have far-reaching application experience concerning the use of different housing materials.

Cable

For the standard models PVC- or PUR-cable are used. One has to take into consideration that the cable should not be moved with ambient temperatures below -5°C . PVC is not suitable for use in applications with oil-based liquids or with UV-radiation. PUR is not suitable for continuous contact with water. For special application areas silicone or PTFE cables are available.

Nominal sensing distance / S_n

The characteristic value of a sensor, without consideration of production tolerances and variations due to temperature and voltages. Reference gearwheel module 4, 1000 Hz

Real sensing distance / S_r

The sensing distance determined at $+20^\circ\text{C}$ and rated voltage. Here the series variance is taken into consideration. Variation max. $\pm 10\%$.

Series- and parallel connection

It is possible to connect the sensors in series or parallel. When considering this it must be taken into account that the voltage drops are added for series connection and the residual voltages for parallel connection. Under these circumstances it is advisable to operate a maximum of three sensors in a corresponding circuit.

Frequency of operating cycles

The maximum damping and un-damping cycles of the proximity sensor within one second. To ascertain the frequency of operating cycles a pulse / break ratio of 1 : 2 is used as a basis.

Enclosure rating

IP 65: Protection against contact with voltage-carrying parts, protection against ingress of dust and water jet.
IP 67: Protection against contact with voltage-carrying parts, protection against ingress of dust and protection against ingress of water when the equipment is immersed in water, up to 1 m depths and for a period of 30 minutes.

Temperature variation

The displacement of the switching point if the ambient temperature changes. This is with MRS less than $\pm 10\%$.

Modul

Diameter of a gearwheel in relation to the number of teeth. $M = D : T$

APPLICATION EXAMPLES

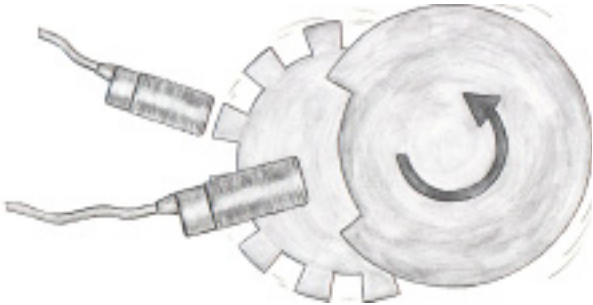

Detection of a gear wheel or cam wheel.

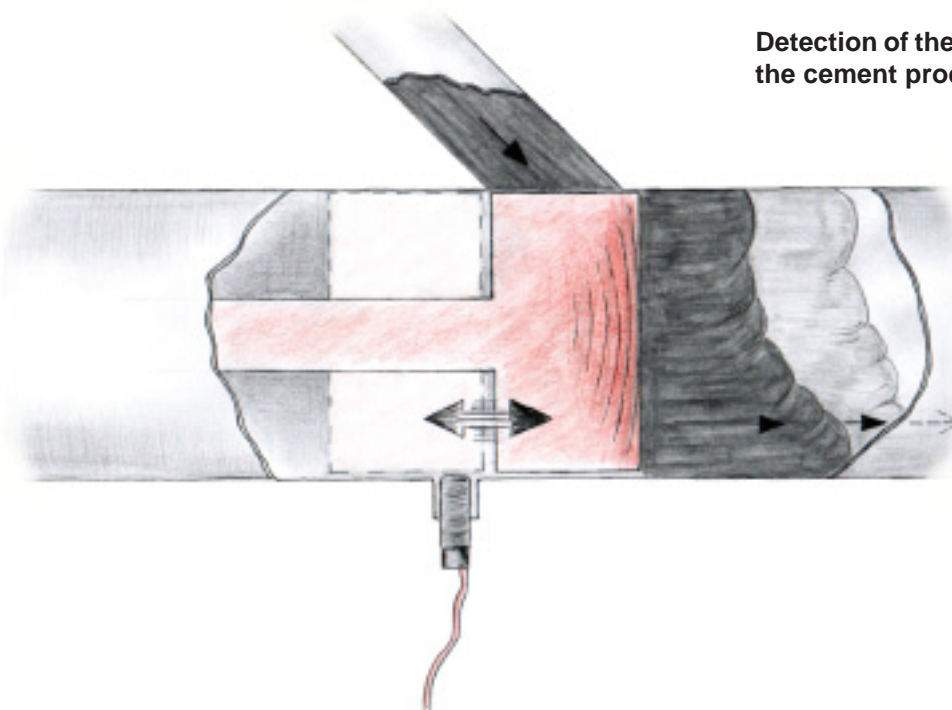

Detection of the motion of a bolt during the cement production.

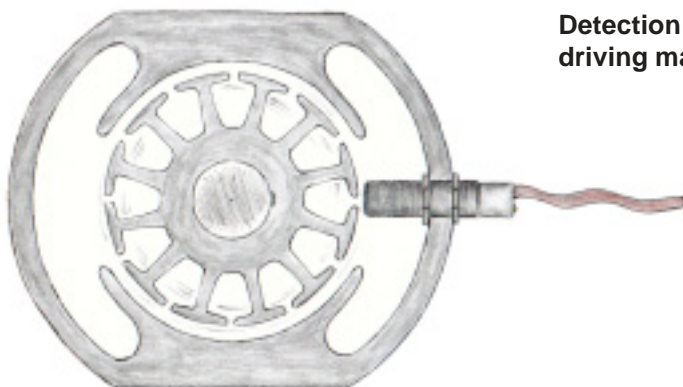

Detection of the rotation of an electric driving machine.

All specifications are subject to change without notice. (05/2004)

CYLINDRICAL HOUSINGS

I T E M	Sensing distance [mm]		Diameter [mm] or with thread	Housing material	Electrical Version		Connection	Pages
					DC	DC		
	flush	non-flush	Stainless steel [VA] No. 1.4305 No. 1.4404 Polyamide [PA]	10...35 V NPN [20] PNP [10] Selection NO (S) NC (Ö) see data sheet	7,5...20 V 2-wire [N]	Cable, Connector Cable Connector [Y...]		
MRS-300-...								
1	1,5	-	M12	VA, PA	10, 20, N	Cable	12-14	
2	3	-	M18	VA	10, 20	Cable	15	
MRS-350-... with detection of direction of rotation								
3	1	-	M12	VA	10, 20	Cable	16	
4	2,5	-	M18	VA	10, 20	Cable	17	
MRS-350-...-Z detection of direction of rotation with dephased output signal								
5	1	-	M12	VA	10	Cable	18	
6	2,5	-	M18	VA	10	Cable	19	

All specifications are subject to change without notice. (05/2004)



Magneto-resistive Sensors

Series 300 • 20 - NPN
Series 300 • 10 - PNP

Housing M12 x 1

- Housing material: stainless steel VA
- Flush mountable
- Sensing distance Sn 1.5 mm

Certificate:



Technical data

Operating distance Sn [mm], flush mounting	1.5, yes
Electrical version	3-wire DC
Output	NO
Type NPN	MRS-300-M12-20-S
Art.-No.	360 300
Connection diagram No.	1
Type PNP	MRS-300-M12-10-S
Art.-No.	360 100
Connection diagram No.	4
Operating voltage (U_B)	10...35 V DC
Output current max. (I_o)	250 mA
Load current min.	-
Voltage drop max. (U_d)	≤ 2.5 V
Permitted residual ripple max.	10 %
No-load current (I_o)	typ. 15 mA
Frequency of operating cycles min./max.	0.5 Hz/15 kHz
Permitted ambient temperature	-40...+125°C
LED-display	yellow
Protective circuit	built-in
Degree of protection IEC 529	IP 67
Connection cable	2 m 3 x 0.14 mm ²
Housing material	VA No. 1.4305
Active surface	VA No. 1.4305
Lid	PEEK

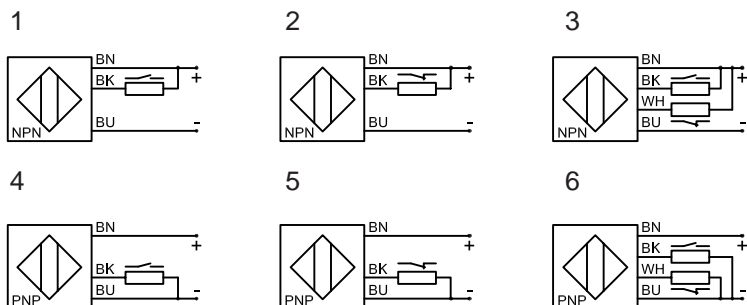
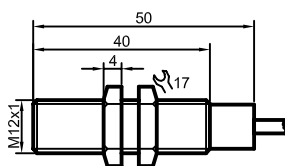

All specifications are subject to change without notice. (05/2004)



Magneto-resistive Sensors

Series 300 • 20 - NPN

Series 300 • 10 - PNP

Housing M12 x 1

- **Housing material: PA**
- **Flush mountable**
- **Sensing distance Sn 1.5 mm**



Certificate:

Technical data

Operating distance Sn [mm], flush mounting	1.5, yes
Electrical version	3-wire DC
Output	NO
Type NPN	MRS-300-M12-20-S-K
Art.-No.	360 350
Connection diagram No.	1
Type PNP	MRS-300-M12-10-S-K
Art.-No.	360 150
Connection diagram No.	4
Operating voltage (U_B)	10...35 V DC
Output current max. (I_o)	250 mA
Load current min.	-
Voltage drop max. (U_d)	≤ 2.5 V
Permitted residual ripple max.	10 %
No-load current (I_o)	typ. 15 mA
Frequency of operating cycles min./max.	0.5 Hz/15 kHz
Permitted ambient temperature	-25...+70°C
LED-display	yellow
Protective circuit	built-in
Degree of protection IEC 529	IP 67
Connection cable	2 m 3 x 0.14 mm ²
Housing material	PA
Active surface	PA
Lid	PA

All specifications are subject to change without notice. (05/2004)

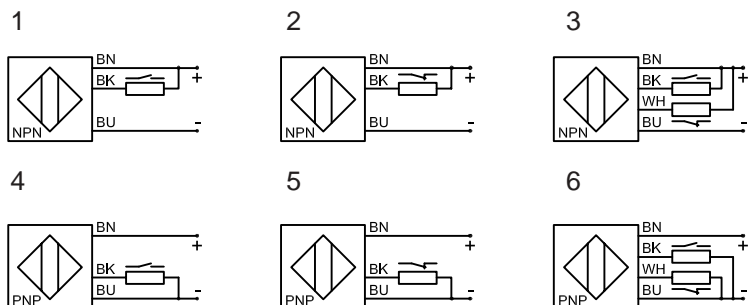
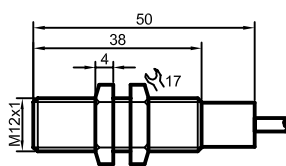



Magneto-resistive Sensors

Series 300 • 2-wire

Housing M12 x 1

- Housing material: PA
- Flush mountable
- Sensing distance S_n 1.5 mm

Certificate:



Technical data

Operating distance S_n [mm], flush mounting	1.5, yes
Electrical version	2-wire DC
Output	NO
Type	MRS-300-M12-N-K
Art.-No.	362 100
Connection diagram No.	see below
Operating voltage (U_b)	7.5...20 V DC
Output current active surface free	typ. 7 mA
Output current active surface covered	typ. 14 mA
Self-inductance (L)	100 μ H
Self-capacitance (C)	500 pF
Voltage drop max. (U_d)	≤ 2.5 V
Permitted residual ripple max.	10 %
No-load current (I_0)	typ. 7 mA
Frequency of operating cycles max.	0.5 Hz/15 kHz
Permitted ambient temperature	-25...+70°C
LED-display	yellow
Protective circuit	built-in
Degree of protection IEC 529	IP 67
Connection cable	2 m 2 x 0.14 mm ²
Housing material	PA
Active surface	PA
Lid	PA

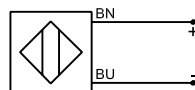
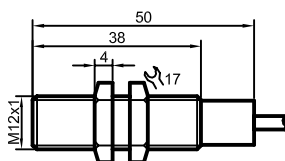

All specifications are subject to change without notice. (05/2004)



Magneto-resistive Sensors

Series 300 • 20 - NPN

Series 300 • 10 - PNP

Housing M18 x 1

- Housing material: stainless steel VA

- Flush mountable

- Sensing distance Sn 3 mm



Certificate:

Technical data

Operating distance Sn [mm], flush mounting	3, yes
Electrical version	3-wire DC
Output	NO
Type NPN	MRS-300-M18-20-S
Art.-No.	360 700
Connection diagram No.	1
Type PNP	MRS-300-M18-10-S
Art.-No.	360 500
Connection diagram No.	4
Operating voltage (U_B)	10...35 V DC
Output current max. (I_o)	250 mA
Load current min.	-
Voltage drop max. (U_d)	≤ 2.5 V
Permitted residual ripple max.	10 %
No-load current (I_o)	typ. 15 mA
Frequency of operating cycles min./max.	0.5 Hz/15 kHz
Permitted ambient temperature	-40...+125°C
LED-display	yellow
Protective circuit	built-in
Degree of protection IEC 529	IP 67
Connection cable	2 m 3 x 0.34 mm ²
Housing material	VA No. 1.4404
Active surface	VA No. 1.4404
Lid	PEEK

All specifications are subject to change without notice. (05/2004)

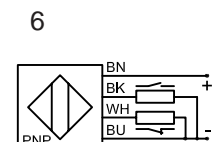
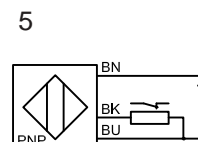
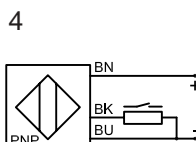
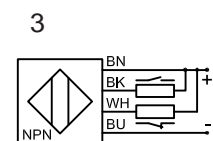
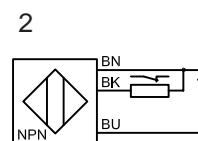
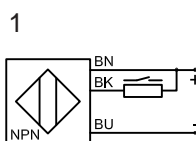
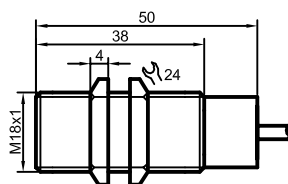



**Magneto-resistive Sensors
with detection of direction of rotation
Series 350 • 20 - NPN
Series 350 • 10 - PNP**

- Housing M12 x 1**
- Housing material: stainless steel VA
 - Flush mountable
 - Sensing distance Sn 1 mm

Certificate::



Technical data

Operating distance Sn [mm], flush mounting	1, yes
Electrical version	4-wire DC
Output	NO
Type NPN	MRS-350-M12-20-S
Art.-No.	361 100
Connection diagram No.	1
Type PNP	MRS-350-M12-10-S
Art.-No.	360 900
Connection diagram No.	4
Operating voltage (U _B)	10...35 V DC
Output current max. (I _O)	2 x 250 mA
Load current min.	-
Voltage drop max. (U _d)	≤ 2.5 V
Permitted residual ripple max.	10 %
No-load current (I ₀)	typ. 15 mA
Frequency of operating cycles min./max.	0.5 Hz/10 kHz
Permitted ambient temperature	-40...+125°C
LED-display	green/yellow
Protective circuit	built-in
Degree of protection IEC 529	IP 67
Connection cable	2 m 4 x 0.14 mm ²
Housing material	VA No. 1.4305
Active surface	VA No. 1.4305
Lid	PEEK

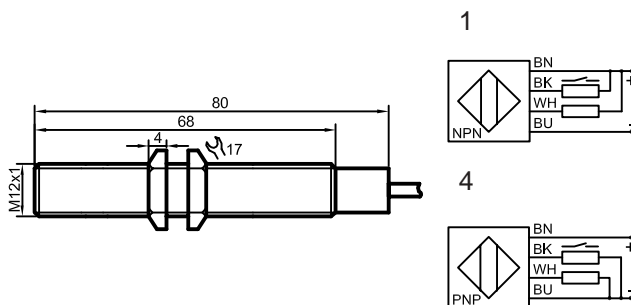

BK = Speed control
WH = detection of direction of rotation

All specifications are subject to change without notice. (05/2004)



**Magneto-resistive Sensors
with detection of direction of rotation
Series 350 • 20 - NPN
Series 350 • 10 - PNP**

Housing M18 x 1

- Housing material: stainless steel VA
- Flush mountable
- Sensing distance Sn 2.5 mm

Certificate:



Technical data

Operating distance Sn [mm], flush mounting	2,5, yes
Electrical version	4-wire DC
Output	NO
Type NPN	MRS-350-M18-20-S
Art.-No.	361 500
Connection diagram No.	1
Type PNP	MRS-350-M18-10-S
Art.-No.	361 300
Connection diagram No.	4
Operating voltage (U_B)	10...35 V DC
Output current max. (I_o)	2 x 250 mA
Load current min.	-
Voltage drop max. (U_d)	≤ 2.5 V
Permitted residual ripple max.	10 %
No-load current (I_o)	typ. 15 mA
Frequency of operating cycles min./max.	0.5 Hz/10 kHz
Permitted ambient temperature	-40...+125°C
LED-display	green/yellow
Protective circuit	built-in
Degree of protection IEC 529	IP 67
Connection cable	2 m 4 x 0.34 mm ²
Housing material	VA No. 1.4404
Active surface	VA No. 1.4404
Lid	PEEK

All specifications are subject to change without notice. (05/2004)

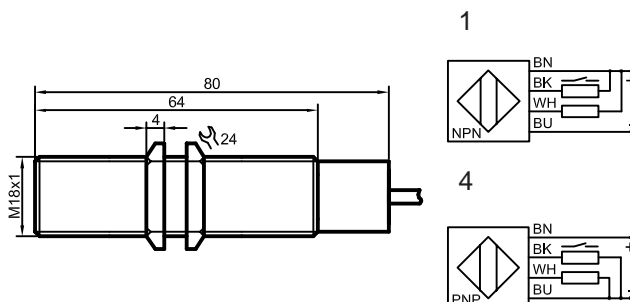

BK = Speed control
WH = detection of direction of rotation



Magneto-resistive Sensors with detection of direction of rotation

Series 350 • 10 - PNP

Housing M12 x 1

- Housing material: stainless steel VA
- Flush mountable
- Sensing distance Sn 1 mm
- With dephased output signal

Certificate:



Technical data

Operating distance Sn [mm], flush mounting	1, yes
Electrical version	4-wire DC
Output	NO
Type NPN	
Art.-No.	
Connection diagram No.	
Type PNP	
Art.-No.	
Connection diagram No.	
Operating voltage (U_B)	10...35 V DC
Output current max. (I_o)	2 x 250 mA
Load current min.	-
Voltage drop max. (U_d)	≤ 2.5 V
Permitted residual ripple max.	10 %
No-load current (I_o)	typ. 15 mA
Frequency of operating cycles min./max.	0.5 Hz/10 kHz
Permitted ambient temperature	-40...+125°C
LED-display	green/yellow
Protective circuit	built-in
Degree of protection IEC 529	IP 67
Connection cable	2 m 4 x 0.14 mm ²
Housing material	VA No. 1.4305
Active surface	VA No. 1.4305
Lid	PEEK

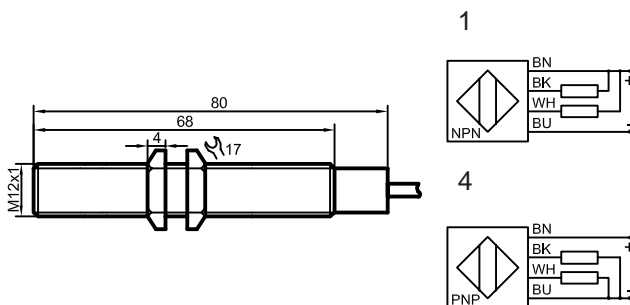

BK = Speed control
WH = detection of direction of rotation dephased

All specifications are subject to change without notice. (05/2004)



**Magneto-resistive Sensors
with detection of direction of rotation**

Series 350 • 10 - PNP

Housing M18 x 1

- Housing material: stainless steel VA
- Flush mountable
- Sensing distance Sn 2.5 mm
- With dephased output signal

Certificate:



Technical data

Operating distance Sn [mm], flush mounting	2.5, yes
Electrical version	4-wire DC
Output	NO
Type NPN	
Art.-No.	
Connection diagram No.	
Type PNP	MRS-350-M18-10-Z
Art.-No.	361 430
Connection diagram No.	4
Operating voltage (U_B)	10...35 V DC
Output current max. (I_o)	2 x 250 mA
Load current min.	-
Voltage drop max. (U_o)	≤ 2.5 V
Permitted residual ripple max.	10 %
No-load current (I_o)	typ. 15 mA
Frequency of operating cycles min./max.	0.5 Hz/10 kHz
Permitted ambient temperature	-40...+125°C
LED-display	green/yellow
Protective circuit	built-in
Degree of protection IEC 529	IP 67
Connection cable	2 m 4 x 0.34 mm ²
Housing material	VA No. 1.4404
Active surface	VA No. 1.4404
Lid	PEEK

All specifications are subject to change without notice. (05/2004)

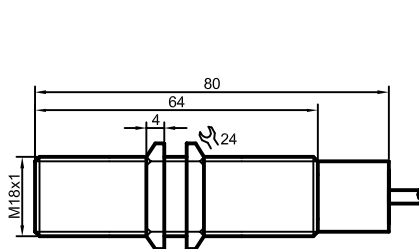

1

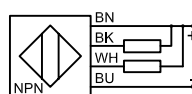

4

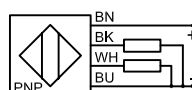

BK = Speed control
WH = detection of direction of rotation dephased

NORMS

The products of Rechner Industrie-Elektronik GmbH are designed and checked in accordance with the standards and specifications, DIN - VDE - IEC, for electric and electronic instruments. For new and revised products the newest standards are always used.

Effective standards for proximity switches and sensors:

DIN VDE 0660 Part 208:

Low-voltage switchgear - additional requirements for inductive proximity switches.

DIN VDE 0660 Part 209

Low-voltage switchgear and controlgear, control switches - additional requirements for proximity switches used in safety-related applications.

DIN VDE 0660 Part 212 (Replaces DIN 19234)

Instrumentation and control technology - electrical position sensors - DC interface for position sensors and switching amplifiers

European Standards

EN 60947-5-2 Low Voltage Switchgear Part 5

Control circuit devices and switching elements, section 2: proximity switches

EN 60947-5-6

Control circuit devices and switching elements, proximity sensors - DC interface for proximity sensors and switching amplifiers (NAMUR)

International Standards

IEC 947-5-2 Low-voltage switchgear and controlgear Part 5

Control circuit devices and switching elements - Section 2, proximity switches

Draft IEC 61934

Control circuit devices and switching elements DC interface for proximity sensors and switching amplifiers (NAMUR)

Standards On Explosion Protection

DIN EN 50014

Electrical apparatus for potentially explosive environments.
General requirements.

DIN EN 50020

Electrical apparatus for potentially explosive environments.
Intrinsic safety „i“

EN 60079-10

Electrical apparatus for potentially explosive environments.
Classification of hazardous areas.

EN 60079-14

Electrical apparatus for potentially explosive environments.
Classification of hazardous areas (mines excepted).

NORMS

Normen zur Qualitätssicherung (QS)

DIN ISO 9000-9004 (EN 29000-29 004)
Quality assurance (QA) for products and services

DIN ISO 9001
Quality assurance in design/development, production, installation and servicing

DIN ISO 9002
Quality assurance in production

DIN ISO 9003
Quality assurance for final testing only

DIN ISO 9004
Quality management and elements of a quality management system

RECHNER Industrie-Elektronik-GmbH is certified according to DIN ISO 9001:2000.

CE - Marking

The CE marking represents the manufacturer's confirmation that the identified product conforms to applicable standards and directives throughout Europe. The following regulations apply to the RECHNER products.

89/336/EWG
EMC Directive (EN 60 947-5-2)

73/23/EWG
Low-voltage Directive (compare with VDE 0160, product standard EN 60947-5-2)

Directive 94/9/EG
Equipment and Protection Systems designed for use in potentially explosive environments

RECHNER Industrie-Elektronik GmbH certifies the conformity of its products with each of the applicable directives in a Manufacturer's Declaration. In addition RECHNER has a laboratory accredited by DATech for testings according to IEC/EN 60947-5-2 and also an accredited EMC laboratory.

All specifications are subject to change without notice. (05/2004)

TYPE SELECTION IN ARTICLE NUMBER ORDER

Art.-No.	Type Description	Page
360100	MRS-300-M12-10-S	12
360150	MRS-300-M12-10-S-K	13
360300	MRS-300-M12-20-S	12
360350	MRS-300-M12-20-S-K	13
360500	MRS-300-M18-10-S	15
360700	MRS-300-M18-20-S	15
360900	MRS-350-M12-10-S	16
360950	MRS-350-M12-10-Z	18
361100	MRS-350-M12-20-S	16
361300	MRS-350-M18-10-S	17
361430	MRS-350-M18-10-Z	19
361500	MRS-350-M18-20-S	17
362100	MRS-300-M12-N-K	14

TYPE SELECTION IN TYPE DESCRIPTION ORDER

Type Description	Art.-No.	Page
MRS-300-M12-10-S	360100	12
MRS-300-M12-10-S-K	360150	13
MRS-300-M12-20-S	360300	12
MRS-300-M12-20-S-K	360350	13
MRS-300-M12-N-K	362100	14
MRS-300-M18-10-S	360500	15
MRS-300-M18-20-S	360700	15
MRS-350-M12-10-S	360900	16
MRS-350-M12-10-Z	360950	18
MRS-350-M12-20-S	361100	16
MRS-350-M18-10-S	361300	17
MRS-350-M18-10-Z	361430	19
MRS-350-M18-20-S	361500	17

All specifications are subject to change without notice. (05/2004)

All specifications are subject to change without notice. (05/2004)

SENSORS FOR INDUSTRIAL AUTOMATION

INDUCTIVE • CAPACITIVE OPTOELECTRONIC • CALORIMETRIC

Ask for further catalogues

CAPACITIVE SENSORS KAS

CAPACITIVE SENSORS KXS

INDUCTIVE SENSORS

OPTOELECTRONIC SENSORES

ISOLATING SWITCHING AMPLIFIERS AND POWER SUPPLIES

CAPACITIVE LEVEL MEASURING SYSTEMS

FLOW SENSORS

Your Representative:

RECHNER

INDUSTRIE-ELEKTRONIK GmbH

Gaußstraße 8-10 68623 Lampertheim Germany

Tel. +49 (0) 62 06 50 07-0

Fax Intl. +49 (0) 62 06 50 07-20

www.rechner-sensors.de

e-mail: info@rechner-sensors.de