

MSK B250/220-1,5

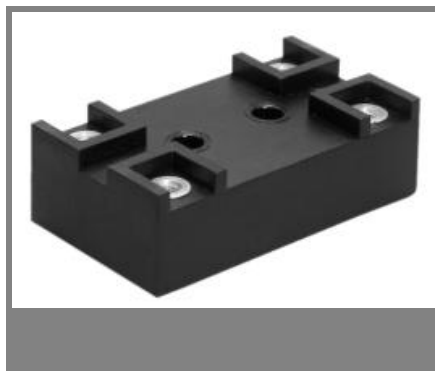

Bridge Rectifiers

MSK B250/220-1,5

Features

- Plastic case with screw terminals
- High blocking voltage

Typical Applications

- Internal power supplies for electronic equipment
- DC power supplies
- Control equipment
- Recommended snubber network:
RC: 10 nF, 20...50 Ω ($P_R = 1$ W)

- 1) Freely suspended or mounted on an insulator
- 2) Mounted on a painted metal sheet of min. 250 x 250 x 1 mm

V_{RSM}, V_{RRM} V	V_{VRMS} V	$I_D = 2$ A ($T_a = 45$ °C) Types	C_{max} μ F	R_{min} Ω
800	250	MSK B250/220-1,5		

Symbol	Conditions	Values	Units
I_D	$T_a = 45$ °C, isolated ¹⁾	2	A
	$T_a = 45$ °C, chassis ²⁾	2	A
I_{DCL}	$T_a =$ °C,		A
	$T_a =$ °C,		A
	$T_a =$ °C,		A
	$T_a =$ °C,		A
I_{FSM}	$T_{vj} = 25$ °C, 10 ms	58	A
	$T_{vj} = 150$ °C, 10 ms	50	A
i^2t	$T_{vj} = 25$ °C, 8,3 ... 10 ms	17	A ² s
	$T_{vj} = 150$ °C, 8,3 ... 10 ms	12,5	A ² s
V_F	$T_{vj} = 25$ °C, $I_F = 10$ A	max. 1,65	V
$V_{(TO)}$	$T_{vj} = 150$ °C	max. 0,85	V
r_T	$T_{vj} = 150$ °C	max. 100	m Ω
I_{RD}	$T_{vj} = 25$ °C, $V_{RD} = V_{RRM}$	5	μ A
	$T_{vj} =$ °C, $V_{RD} = V_{RRM} \geq V$		μ A
I_{RD}	$T_{vj} = 150$ °C, $V_{RD} = V_{RRM}$	0,6	mA
	$T_{vj} =$ °C, $V_{RD} = V_{RRM} \geq V$		mA
t_{rr}	$T_{vj} = 25$ °C		μ s
f_G		2000	Hz
$R_{th(j-a)}$		23	K/W K/W
T_{vj}		- 40 ... + 150	°C
T_{stg}		- 55 ... + 150	°C
V_{isol}			V~
M_s			Nm
M_t			Nm
a			m/s ²
w		25	g
F_u		2	A
Case		G 7	

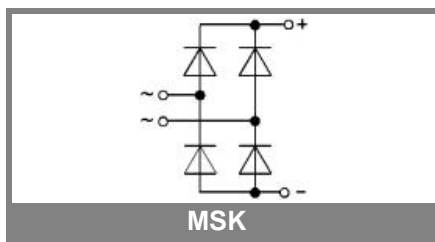

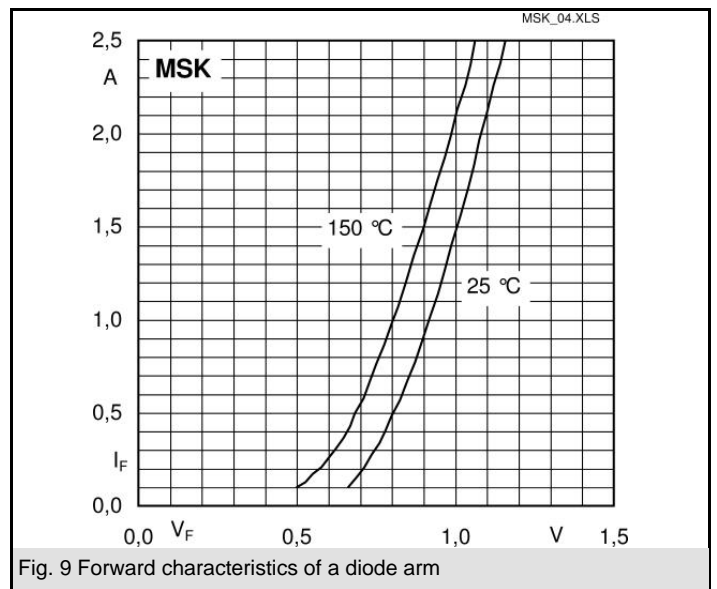
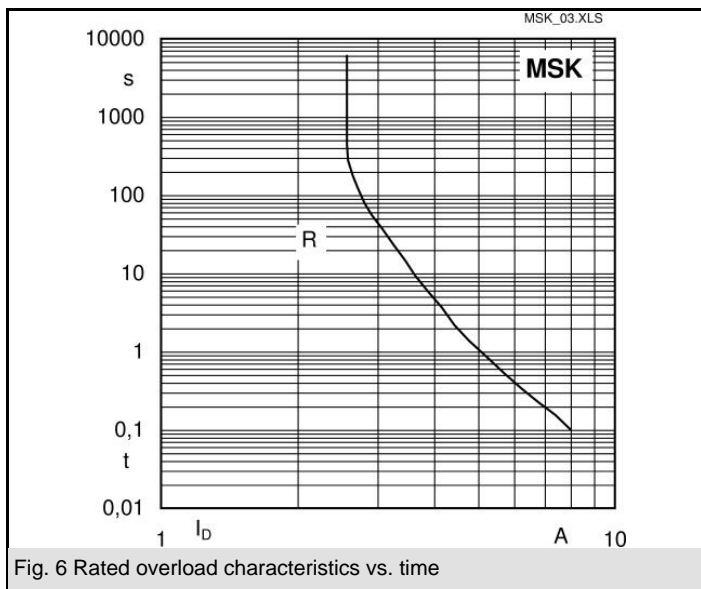
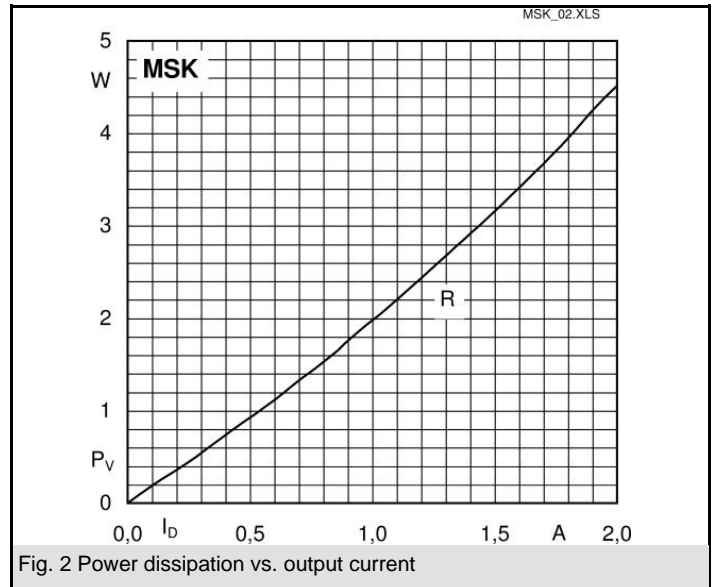
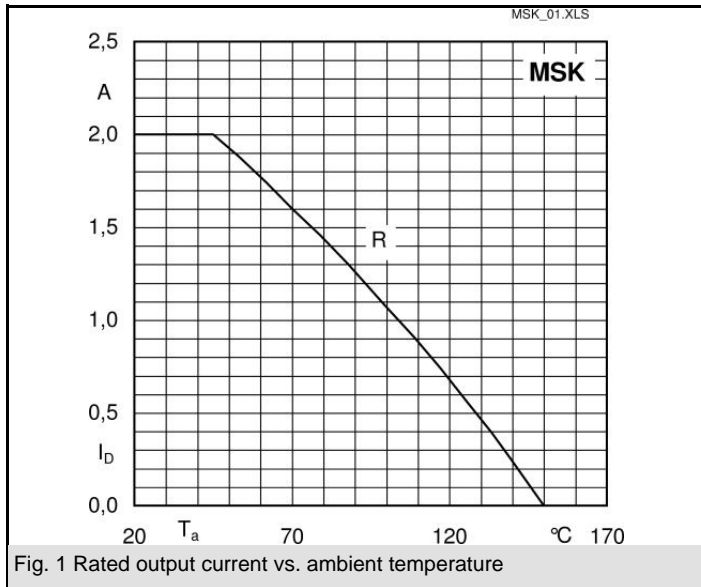

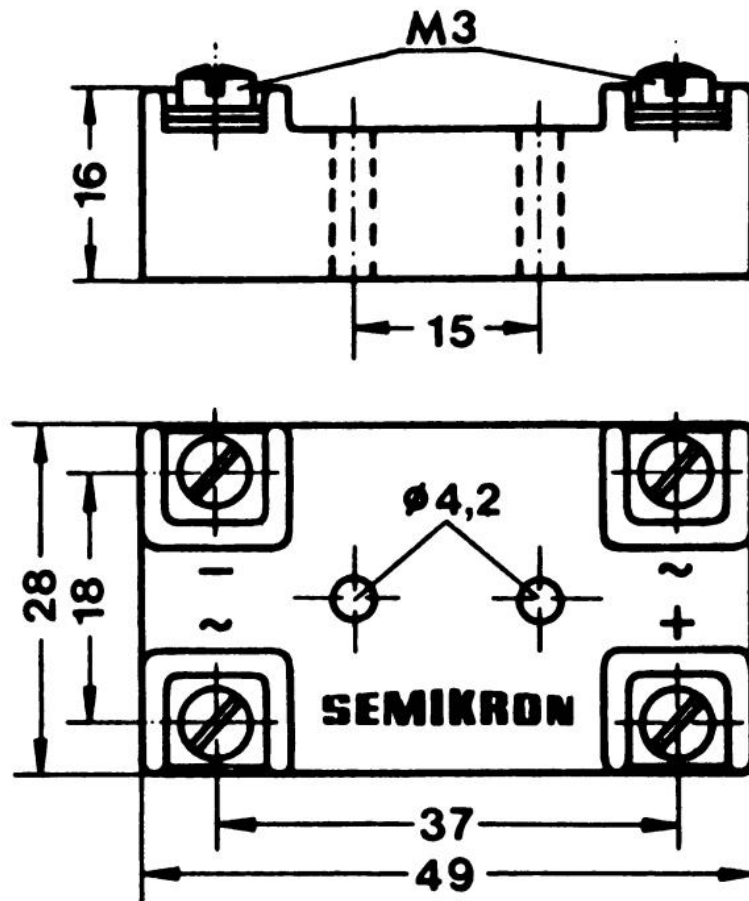

Case G 7

This technical information specifies semiconductor devices but promises no characteristics. No warranty or guarantee expressed or implied is made regarding delivery, performance or suitability.