

SKiiP 313GD122-3DUL

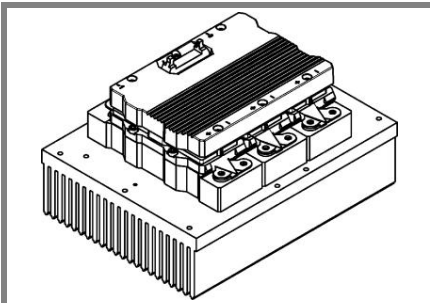

SKiiP® 3

6-pack-integrated intelligent Power System

Power Section

SKiiP 313GD122-3DUL

Preliminary Data

Features

- SKiiP technology inside
- SPT (Soft Punch Through) IGBTs
- CAL diode technology
- Integrated current sensor
- Integrated temperature sensor
- Integrated heat sink
- IEC 60721-3-3 (humidity) class 3K3/IE32 (SKiiP® 3 System)
- IEC 60068-1 (climate) 40/125/56
- UL recognized file no. E63532

1) with assembly of suitable MKP capacitor per terminal (SEMIKRON type is recommended)

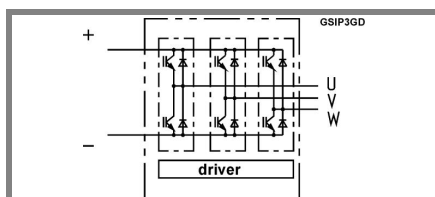

Case S33

Absolute Maximum Ratings		$T_s = 25\text{ °C}$ unless otherwise specified	
Symbol	Conditions	Values	Units
IGBT			
V_{CES}	Operating DC link voltage	1200	V
$V_{CC}^{1)}$		900	V
V_{GES}		± 20	V
I_C	$T_s = 25\text{ (70) °C}$	300 (225)	A
Inverse diode			
$I_F = -I_C$	$T_s = 25\text{ (70) °C}$	230 (180)	A
I_{FSM}	$T_j = 150\text{ °C}$, $t_p = 10\text{ ms}$; sin	2500	A
I^2t (Diode)	Diode, $T_j = 150\text{ °C}$, 10 ms	31	kA ² s
T_j , (T_{stg})		- 40 ... + 150 (125)	°C
V_{isol}	rms, AC, 1 min, main terminals to heat sink	3000	V
$I_{AC-terminal}$	per AC terminal, rms, $T_s = 70\text{ °C}$,	400	A
	$T_{terminal} < 115\text{ °C}$		

Characteristics		$T_s = 25\text{ °C}$ unless otherwise specified			
Symbol	Conditions	min.	typ.	max.	Units
IGBT					
V_{CEsat}	$I_C = 193\text{ A}$, $T_j = 25\text{ (125) °C}$; measured at terminal		2,3 (2,5)	2,6	V
V_{CEO}	$T_j = 25\text{ (125) °C}$; at terminal		1,1 (1)	1,3 (1,2)	V
r_{CE}	$T_j = 25\text{ (125) °C}$; at terminal		6 (7,8)	7 (8,8)	mΩ
I_{CES}	$V_{GE} = 0\text{ V}$, $V_{CE} = V_{CES}$; $T_j = 25\text{ (125) °C}$		0,6 (18)		mA
$E_{on} + E_{off}$	$I_C = 193\text{ A}$, $V_{CC} = 600\text{ V}$		58		mJ
	$T_j = 125\text{ °C}$, $V_{CC} = 900\text{ V}$		102		mJ
R_{CC+EE}	terminal chip, $T_j = 25\text{ °C}$		0,5		mΩ
L_{CE}	top, bottom		12		nH
C_{CHC}	per phase, AC-side		1,7		nF
Inverse diode					
$V_F = V_{EC}$	$I_F = 193\text{ A}$, $T_j = 25\text{ (125) °C}$; measured at terminal		2 (1,8)	2,3	V
V_{TO}	$T_j = 25\text{ (125) °C}$		1 (0,7)	1,2 (0,9)	V
r_T	$T_j = 25\text{ (125) °C}$		5,3 (5,6)	7 (7,4)	mΩ
E_{rr}	$I_C = 193\text{ A}$, $V_{CC} = 600\text{ V}$		15		mJ
	$T_j = 125\text{ °C}$, $V_{CC} = 900\text{ V}$		20		mJ
Mechanical data					
M_{dc}	DC terminals, SI Units	6		8	Nm
M_{ac}	AC terminals, SI Units	13		15	Nm
w	SKiiP® 3 System w/o heat sink		2,4		kg
w	heat sink		7,5		kg
Thermal characteristics (PX16 heat sink with fan SKF 16B-230-1); "s" reference to heat sink; "r" reference to built-in temperature sensor (acc. IEC 60747-15)					
$R_{th(j-s)I}$	per IGBT			0,092	K/W
$R_{th(j-s)D}$	per diode			0,23	K/W
Z_{th}	R_i (mK/W) (max. values)	tau _i (s)			
		1	2	3	4
$Z_{th(j-r)I}$					
$Z_{th(j-r)D}$					
$Z_{th(r-a)}$		2,1	20	5,5	1,4
		210	85	11	0,4

This technical information specifies semiconductor devices but promises no characteristics. No warranty or guarantee, expressed or implied is made regarding delivery, performance or suitability.

SKiiP 313GD122-3DUL

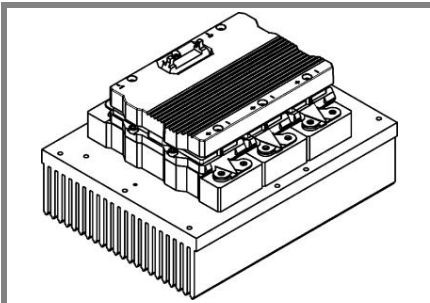

SKiiP® 3

6-pack-integrated intelligent Power System

**6-pack
integrated gate driver
SKiiP 313GD122-3DUL**

Preliminary Data

Gate driver features

- CMOS compatible inputs
- Wide range power supply
- Integrated circuitry to sense phase current, heat sink temperature and DC-bus voltage (option)
- Short circuit protection
- Over current protection
- Over voltage protection (option)
- Power supply protection against under voltage
- Interlock of top/bottom switch
- Isolation by transformer
- IEC 60068-1 (climate) 40/85/56
- UL recognized file no. 242581

Absolute Maximum Ratings		$T_a = 25\text{ °C}$ unless otherwise specified	
Symbol	Conditions	Values	Units
V_{S2}	unstabilized 24 V power supply	30	V
V_i	input signal voltage (high)	15 + 0,3	V
dv/dt	secondary to primary side	75	kV/ μ s
V_{isolIO}	input / output (AC, rms, 2)	3000	V
V_{isolPD}	partial discharge extinction voltage, rms, $Q_{PD} \leq 10\text{ pC}$;	1170	V
V_{isol12}	output 1 / output 2 (AC, rms, 2 s)	1500	V
f_{sw}	switching frequency	20	kHz
f_{out}	output frequency for $I=I_C$; sin.	1	kHz
T_{op} (T_{stg})	operating / storage temperature	- 40 ... + 85	°C

Characteristics		$(T_a = 25\text{ °C})$			
Symbol	Conditions	min.	typ.	max.	Units
V_{S2}	supply voltage non stabilized	13	24	30	V
I_{S2}	$V_{S2} = 24\text{ V}$	$365+20*f/\text{kHz}+0,00111*(I_{AC}/A)^2$			mA
V_{iT+}	input threshold voltage (High)			12,3	V
V_{iT-}	input threshold voltage (Low)	4,6			V
R_{IN}	input resistance		10		k Ω
C_{IN}	input capacitance		1		nF
$t_{d(on)IO}$	input-output turn-on propagation time		1,3		μ s
$t_{d(off)IO}$	input-output turn-off propagation time		1,3		μ s
$t_{pERRRESET}$	error memory reset time		9		μ s
t_{TD}	top / bottom switch interlock time		3,3		μ s
$I_{analogOUT}$	max. 5mA; 8 V corresponds to 15 V supply voltage for external components		300		A
I_{s1out}	max. load current			50	mA
I_{TRIPSC}	over current trip level ($I_{analog OUT} = 10\text{ V}$)		375		A
T_{tp}	over temperature protection	110		120	°C
U_{DCTRIP}	U_{DC} -protection ($U_{analog OUT} = 9\text{ V}$); (option for GB types)		900		V

For electrical and thermal design support please use SEMISEL.
Access to SEMISEL is via SEMIKRON website <http://www.semikron.com>.

This technical information specifies semiconductor devices but promises no characteristics. No warranty or guarantee, expressed or implied is made regarding delivery, performance or suitability.

